



TWO CHANNEL DUAL CONVERSION L-BAND SATCOM FREQUENCY CONVERTERS



“HOT SWAPPABLE” CONVERTERS, CONVERTER TRAYS WITH INDEPENDENT OPERATION

STANDARD FEATURES

- RS422, RS485 and 10/100 Base-T Ethernet
- Hot swappable independent converter trays with power supplies and reference oscillators.
- Serial output for Redundancy Switchover units
- Switchable 50/75 ohm IF impedance
- RF and IF monitor ports
- Automatic switching to external 5/10 MHz reference
- Electronic adjustment of internal reference frequency
- Low intermodulation distortion
- Phase noise IESS-308/309 compliant
- 64 programmable memory locations
- 30 dB level control
- Independent input level control (upconverters only)
- Elapsed time and event log
- CE mark

OPTIONS

- 140 MHz IF frequency
- Switchable 70/140 MHz IF frequencies
- Reference clean-up loop and improved frequency stability

The GeoSync Microwave Converters are designed to simultaneously provide high performance, high reliability and high value, and are available for operation in the full L-band frequency range.

The low phase noise and excellent dynamic range of these converters enable them to carry almost any type of digital communications signals.

Multiple remote connections and a robust protocol provide strong M&C support.

The two independent converter assemblies are “hot swappable” through the rear of the chassis. Each converter tray has independent control of the front panel. The front panel can be replaced without loss of signal.

DUAL CHANNEL CONFIGURATION

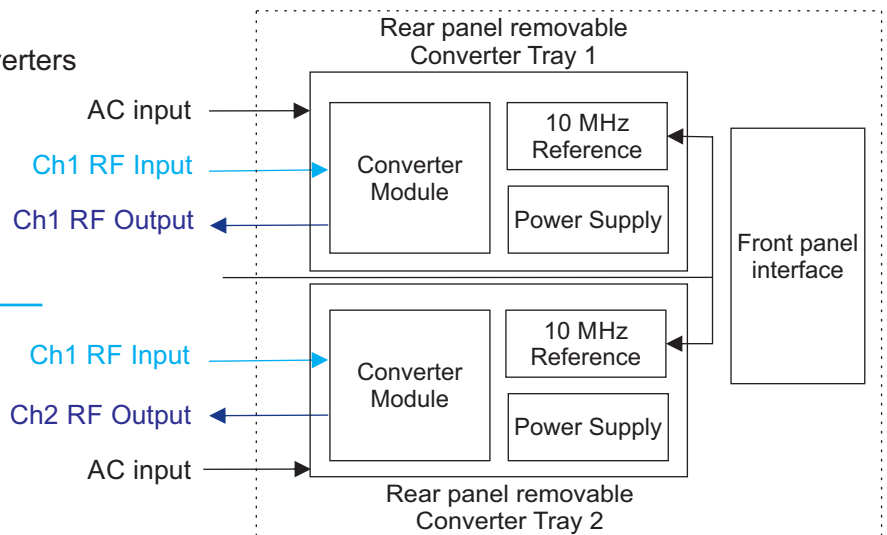

UPCONVERTER TRAY

Model Number	RF Frequency (MHz)
U095175	950-1750
U095215	950-2150

DOWNCONVERTER TRAY

Model Number	RF Frequency (MHz)
D095215	950-2150

Model Numbers consist of the frame prefix RT- followed by any combination of two module bands;

Example: Two channel unit: RT-D095215/D095215
Two Channel Downconverter with two independent converter trays

Example: Up/Downconverter unit:
M/N RT-U095175/D095215
One channel is an L-band upconverter. The second is a downconverter.

SPECIFICATIONS

	UPCONVERTER	DOWNCONVERTER
Type	Dual conversion	
Frequency Step Size	1 kHz	
Frequency Sense	No inversion	

INPUT CHARACTERISTICS

Frequency	70 ±20 MHz (140 ±40 MHz, Option 1-1)	950-2150 MHz
Impedance	50/75 ohm switchable	50 ohms
Return Loss	20 dB minimum	18 dB minimum
Signal Monitor	-20 dBc nominal	
Input Level (Non-damage)	+15 dBm maximum	

OUTPUT CHARACTERISTICS

Frequency	Refer to model number table	70 ±20 MHz (140 ±40 MHz, Option 1-1)
Impedance	50 ohms	50/75 ohm switchable
Return Loss	19 dB minimum	20 dB minimum
Signal Monitor	-20 dBc nominal	
Power Output (1 dB Compression)	+10 dBm minimum	+16 dBm minimum

TRANSFER CHARACTERISTICS

Gain	+31 to +34 dB	+44 to +48 dB
Level Control	30 dB in 0.1 dB steps	
Input Level Control	20 dB in 0.1 dB steps	N/A
Level Stability	±0.25 dB/day 0°C ±0.5 dB typical from 0 to 50°C	
Amplitude Response	±0.5 dB peak-to-peak/40 MHz maximum, 70 MHz IF ±0.75 dB peak-to-peak/80 MHz maximum, 140 MHz IF (Option 1-1) ±2 dB maximum/RF band	
Slope Adjust	±3 dB typical in 0.2 dB steps	
Noise Figure at Minimum Attenuation	N/A	14 dB maximum
Noise Power Density	-123 dBm/Hz maximum	N/A
Image Rejection	N/A	80 dB minimum
Group Delay (70±18 MHz)-		
Linear	0.03 ns/MHz maximum	
Parabolic	0.01 ns/MHz ² maximum	
Ripple	1 ns peak-to-peak maximum	

TRANSFER CHARACTERISTICS (Continued)-	UPCONVERTER	DOWNCONVERTER
Group Delay (140 ±36 MHz)-		
Linear	0.025 ns/MHz maximum	
Parabolic	0.0035 ns/MHz ² maximum	
Ripple	1 ns peak-to-peak maximum	
Third Order Intermodulation Distortion (Two tones each at -10 dBm output)	60 dBc minimum (+20 dBm IP3)	80 dBc minimum (+30 dBm IP3)
AM/PM Conversion	0.1°/dB maximum to 0 dBm output	
Spurious Outputs (Inband)-		
Signal Related	60 dBc up to 0 dBm output	
Signal Independent	-70 dBm maximum	
Harmonic Emission	-60 dBm maximum up to 0 dBm output	N/A
LO Leakage at RF	-75 dBm maximum	-80 dBm maximum
Frequency Stability	±2 x10 ⁻⁸ , 0 to 50°C	
Frequency Aging	5 x10 ⁻⁹ per day, after 24 hours on time	
Frequency Accuracy	Less than 1 Hz (external reference)	
External Reference	5 or 10 MHz, +4 ±3 dBm Automatic switch to the internal reference if the external reference level falls below +1 dBm nominal	
Phase Noise (dBc/Hz)-		
With Maximum Reference	Offset	Maximum
Phase Noise:	10 Hz	-70
10 Hz: -120 dBc/Hz,	100 Hz	-77
100 Hz: -145 dBc/Hz,	1 kHz	-82
1 kHz: -160 dBc/Hz	10 kHz	-90
	100 kHz	-102
	300 kHz	-102
	1 MHz	-110
Upconverter Mute	60 dBm minimum	N/A

REMOTE CONTROLS

Serial Interface	RS485/RS422
Ethernet Interface	10/100 Base-T Ethernet interface providing:
	- HTTP-based web server
	- Telnet Access
	- Password protection

INDICATOR and ALARMS

Remote Mode	Green LED (front panel)
Alarm	Red LED (front panel)
Summary Alarm	Contact closure/open for DC voltage and local oscillator

OPTIONS

59-1. 140 MHz IF frequency

59-2. Selectable 70 MHz and 140 MHz IF frequencies.

One IF connector provided (BNC female).

Selection of IF frequency is available over the remote bus.

59-3 Reference clean-up loop and improved frequency stability

Reference oscillator acts as an analog phase lock with a 0.1 Hz nominal loop bandwidth.

Typical loop suppression of the external reference is as follows:

28 dB at 1 Hz offset, 65 dB at 10 Hz offset and 100 dB at 100 Hz offset

Frequency stability: $\pm 2 \times 10^{-9}$, 0 to 50°C

Frequency aging: 1×10^{-9} per day after 24 hours operation preceded by 10 days of operation



Typical rear panel view - Shown with no options

PRIMARY POWER REQUIREMENTS PER CHANNEL

Voltage.....	90-250 VAC
Frequency.....	47-63 Hz
Power Consumption	40W typical
Fuse.....	T1.25A

PHYSICAL

Weight	16 pounds (7.3 kg) nominal without rack slides
	20 pounds (9.1 kg) nominal with rack slides
Chassis Dimensions	19" x 1.75" panel height x 20" maximum
Connectors -	
RF.....	SMA female
IF	BNC female
RF Monitor.....	SMA female
IF Monitor	BNC female
External Reference	BNC female
Status Interface	DE-15S
Remote Interface	On status interface for RS485, RS422
	RJ-45 female for Ethernet
Primary Power	IEC-320

ENVIRONMENTAL

Operating -	
Ambient Temperature	0 to +50°C
Relative Humidity	Up to 95% at 30°
Altitude	Up to 10,000 feet
Non-operating -	
Ambient Temperature	-50 to +70°C
Relative Humidity	Up to 95% at 40°C
Altitude	Up to 40,000 feet
Shock and Vibration	Normal handling by commercial carriers