

This series of Outdoor Block Downconverters accept one RF composite input covering either 2 or 3 satellite transponder frequencies and provides either 2 or 3 separate & independent L-band IF outputs in an integral, self-contained weather resistant package designed for antenna mounting.

Ka-band and Ku-band models are available covering the entire SatCom bands. A companion series of Upconverters are also available, as are reverse band models.

A strong set of monitor and control functions support powerful remote control. A contact closure summary alarm is provided for fault monitoring.

The standard phase noise is superior to IESS-308/309 and options are available for lower phase noise surpassing the requirements of MIL-STD-188-164B.



BLOCK DOWNCONVERTERS

Input (GHz)	Output (GHz)	LO (GHz)	Model Number
10.7-11.6	0.95-1.85	9.75	DBE2-11.6
11.6-12.5	0.95-1.85	10.65	
10.7-11.7	0.95-1.95	9.75	DBE2-11.725
11.7-12.75	0.95-2	10.75	
10.7-11.45	0.95-1.7	9.75	DBE3-11.725
11.45-12.2	0.95-1.7	10.5	
12.2-12.75	0.95-1.5	11.25	
17.7-18.7	0.95-1.95	16.75	DBE3-19.875
18.3-19.3	0.95-1.95	18.75	
20.2-21.2	0.95-1.95	19.25	
17.7-18.7	0.95-1.95	16.75	DBE3-19.45
18.3-19.3	0.95-1.95	18.75	
20.2-21.2	0.95-1.95	19.25	
17.7-18.9	0.95-2.15	16.75	DBE3-18.95
18.9-20.1	0.95-2.15	17.95	
20.1-20.2	0.95-2.05	19.15	
17.7-18.7	0.95-1.95	16.75	DBE3-19.35
19-20	0.95-1.95	18.05	
20-21	0.95-1.95	19.05	
27.5-28.5	0.95-1.95	26.55	DBE3-28.75
28.3-29.3	0.95-1.95	27.35	
29-30	0.95-1.95	28.05	
27.5-28.7	0.95-2.15	26.55	DBE3-29.25
28.7-29.9	0.95-2.15	27.75	
29.9-31	0.95-2.05	28.95	

STANDARD FEATURES

- Single wideband RF input with 2 or 3 independent IF outputs
- Small-size weather resistant enclosure
- Amplitude slope adjust
- RS422, RS485 and 10/100 Base-T Ethernet
- Serial output for Redundancy Switchover units
- RF and L-band monitor ports
- Automatic 5/10 MHz internal/external reference selection
- Electronic adjust of internal reference frequency
- IESS-308/309 phase noise
- Low intermodulation distortion
- 45 dB of independent RF and L-band level control
- Mute function on alarm or external mute input command
- Elapsed time and event log after power turn on
- CE Mark

OPTIONS

- High performance package
- Lower gain
- Reference clean-up loop and improved stability
- Lower phase noise

BLOCK DIAGRAM

Tri Output Models -

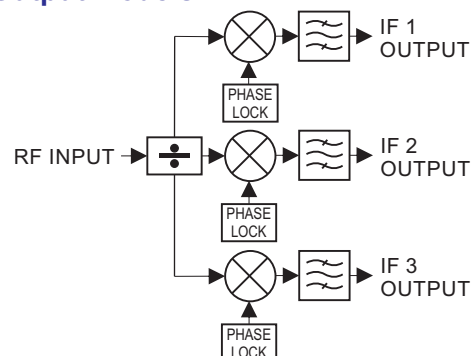

SPECIFICATIONS

Return Loss (50 Ohms)	18 dB minimum
Signal Monitor	-20 dBc nominal
LO Leakage	-80 dB maximum

OUTPUT CHARACTERISTICS -

Return Loss (50 ohms)	18 dB minimum
Signal Monitor	-20 dBc nominal
Power Output (1 dB Compression)	+18 dBm minimum

TRANSFER CHARACTERISTICS -

Gain	30 ±3 dB at center frequency						
L-band Level Control	30 dB in 0.2 dB steps						
RF-band Level Control	15 dB in 0.2 dB steps						
Level Stability	±0.25 dB over any 20°C, ±1.5 dB over -40° to 60°C						
Amplitude Response	±0.25 dB/40 MHz maximum, ±1 dB maximum over RF frequencyband						
Slope Adjust	0 to 6 dB minimum						
Noise Figure at Minimum Attenuation	14 dB maximum at maximum gain						
Image Rejection	70 dB minimum						
Third Order Intermodulation Distortion With two inband signals each at 0 dBm, measured at the output	60 dBc minimum (+30 dBm IP3)						
Spurious Outputs (Inband) –							
Signal Related up to 0 dBm output	65 dBc minimum						
Signal Independent	-75 dBm maximum						
Signal Harmonic Related up to -10 dBm output	55 dBc minimum (including 2nd harmonic)						
Maximum Phase Noise (dBc/Hz) –	Offset (Hz)						
With Maximum Reference Phase	LO Frequency	10	100	1K	10K	100K	1M
10 Hz: -120 dBc/Hz	6.7 to 12 GHz	-65	-73	-85	-95	-104	-119
100 Hz: -145 dBc/Hz	16.5 to 20 GHz	-55	-75	-85	-85	-97	-120
1 kHz: -160 dBc/Hz	Up to 30 GHz	-51	-75	-80	-85	-95	-118
Frequency Stability	±5 x 10 ⁻⁸ , -40° to +60°C (reference 25°C)						
Frequency Aging	5 x 10 ⁻⁹ /day after 24 hours on time						
Automatic Reference Configuration	External 5 or 10 MHz at +4 ±3 dBm. If external reference is below +1 dBm nominal, the converter will automatically lock to the internal reference.						
Converter Mute	60 dB minimum on summary alarm or mute command.						

REMOTE CONTROLS

Serial Interface	RS485/RS422
Ethernet Interface	10/100Base-T Ethernet <ul style="list-style-type: none"> • HTTP-based web server • SNMP 1.0 configuration • Alarm reporting via SNMP Trap • Telnet access • Password protection

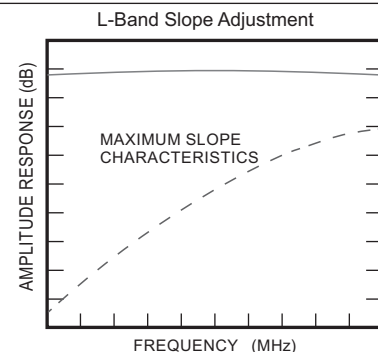

INDICATORS and ALARMS

Status Indicator	Red LED: Alarm, Yellow LED: External Reference
Power ON Indicator	Green LED
Summary Alarm	Contact closure/open for DC voltage and local oscillator (programmable LNA current alarm on downconverters +12VDC at 250 mA)

Note: All specifications are at maximum gain unless otherwise noted.

OPTIONS

41-1. High Performance Package -

Gain.....	30 ±1 dB
Power Output (1 dB Compression)	+20 dBm minimum
Gain Slope	0.03 dB/MHz maximum
Level Stability	±0.25 dB/day maximum at constant temperature, ±1.0 dB maximum/-40 to 60°C
Spurious Outputs (Inband)	
Signal Related	-65 dBc minimum at 0 dBm output
Signal Independent	-80 dBm maximum
Local Oscillator Leakage.....	-70 dBm maximum (upconverters only)
Image Rejection	80 dB minimum

High Performance Phase Noise (dBc/Hz, maximum)

LO Frequency	Offset(Hz)					
	10	100	1K	10K	100K	1M
≤ 12 GHz	-60	-78	-105	-112	-117	-136
≤ 20 GHz	-47	-70	-98	-103	-106	-127
≤ 30 GHz	-40	-65	-90	-100	-102	-124

Group delay.....	1 ns maximum peak to peak/RF band segment
Mute	80 dB minimum on summary alarm or mute command
Intermodulation Distortion (Third Order)	With two inband signals at 0 dBm output, third order intermodulation products are less than 60 dBc minimum.
AM/PM Conversion (at 0 dBm Output).....	0.1°/dB maximum

41-1A High Performance Phase Noise only. Standard IF/RF performance.

Note: Consult factory for lower phase noise options.

41-2. Lower Gain.....	20 ±3 dB at 23°C, 18 dB noise figure (20 dB noise figure for upconverters with 1 GHz bandwidth) (2 x 1 signal related, 65 dBc at -10 dBm output)
41-3. Lower Gain.....	10 ±3 dB at 23°C, 20 dB noise figure (22 dB noise figure for upconverters with 1 GHz bandwidth) (2 x 1 signal related, 65 dBc at -10 dBm output)
41-4. Reference Clean-up Loop and Improved Frequency Stability	Reference oscillator acts as an analog phase lock with a 0.1 Hz nominal loop bandwidth. Typical loop suppression of the external reference is as follows: 28 dB at 1 Hz offset; 65 dB at 10 Hz offset and 100 dB at 100 Hz offset Frequency Stability: ±5 x10 ⁻⁹ , -40 to 60°C Frequency Aging: 1 x 10 ⁻⁹ per day after 24 hours operation preceded by 10 days operation

41-6. MIL-STD-188-164B Compliant Phase Noise

PRIMARY POWER REQUIREMENTS

Voltage..... 90-250 VAC
 Frequency..... 47-63Hz
 Consumption 40W typical
 Fuse..... T1.25A

PHYSICAL

Weight 22 pounds (10 kg) nominal

Connectors-

RF SMA female below 22 GHz, 2.92 mm female
 L-band N female
 RF Monitor SMA female compatible
 L-band Monitor SMA female
 External Reference SMA female
 Status/Control Interface MS3116F14-18P type for summary alarm, RS422, RS485, and LNA power
 Remote Interface RJ-45 female for Ethernet RS485 available on Status connector
 Primary Power FCI clipper series CL1M1102

ENVIRONMENTAL

Enclosure Rating IP-65
 Operating-
 Ambient Temperature -40 to 60°C
 Altitude Up to 10,000 feet
 Non-operating-
 Ambient Temperature -50 to 70°C
 Altitude..... Up to 40,000 feet
 Shock and Vibration Normal handling by commercial carriers

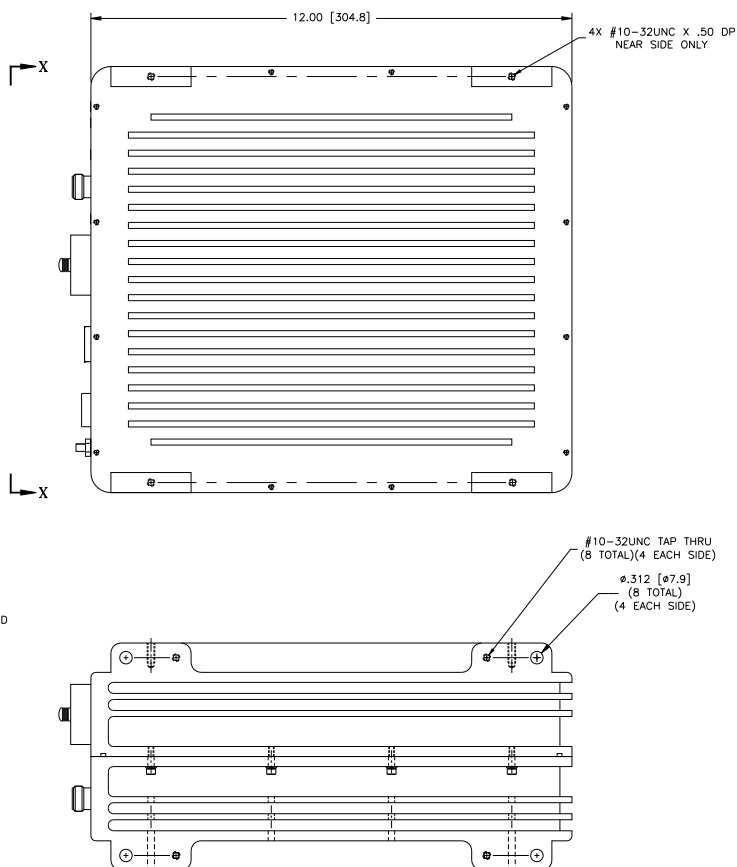
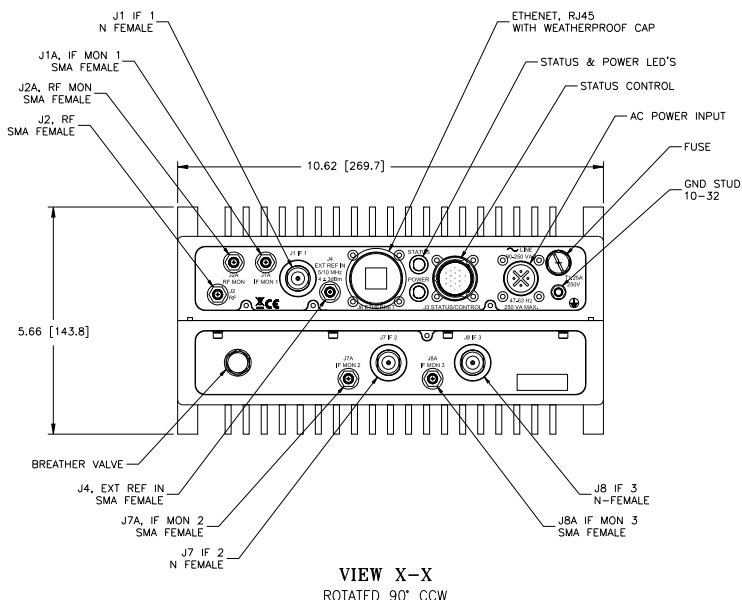

Typical Outline (with option 41-1)

GeoSync Microwave, Inc. • 320 Oser Avenue • Hauppauge, NY 11788
 Phone: 631 760-5567 • Fax: 631 780-0214 www.geosyncmicrowave.com

